



**SUPREME**

with anti-allergen properties



# 701012

FH 2012

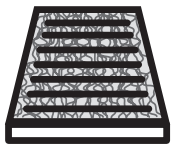

PCA

WANT TO KNOW MORE?



[www.valeo-techassist.com](http://www.valeo-techassist.com)

FOR  
**RENAULT**

SCÉNIC III A/C+/- (03/09 >) / GRAND SCÉNIC A/C+/- (06/09 >)

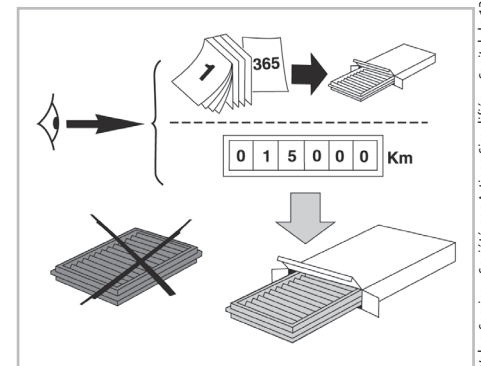
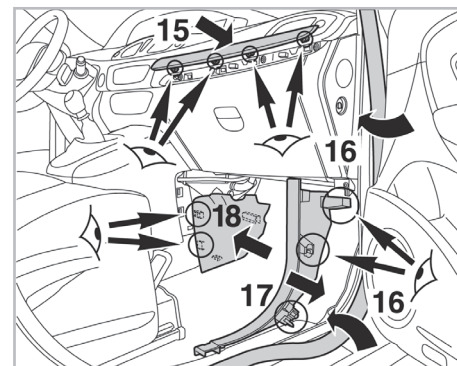
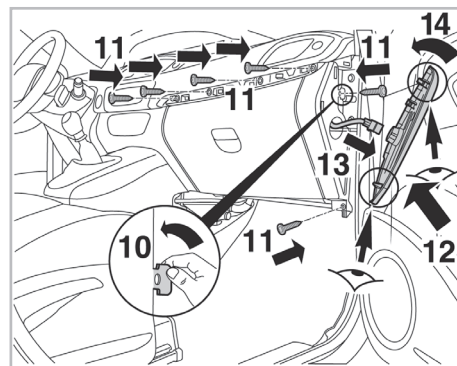
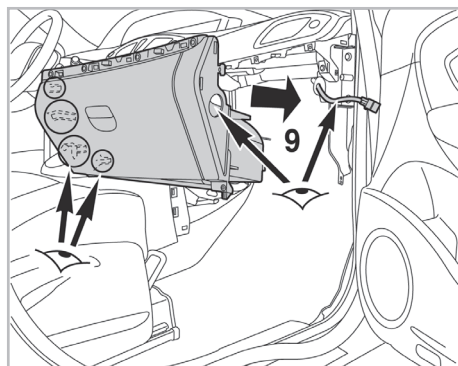
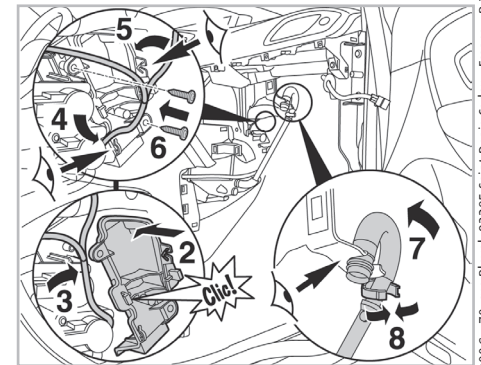
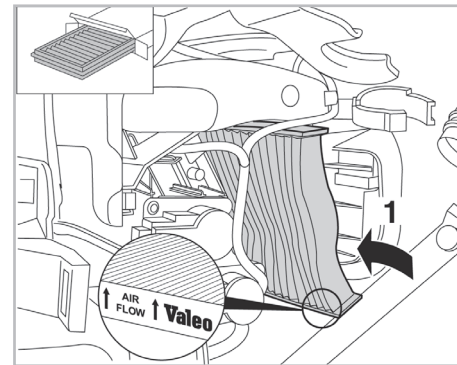
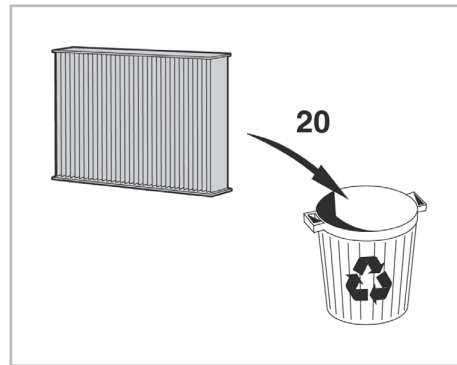
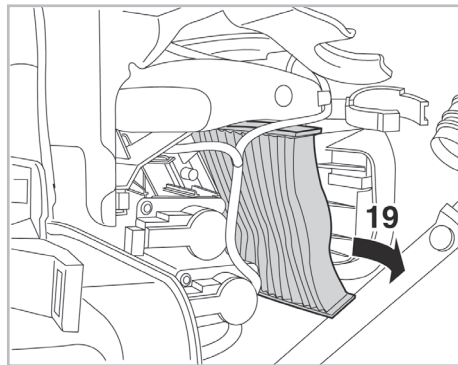
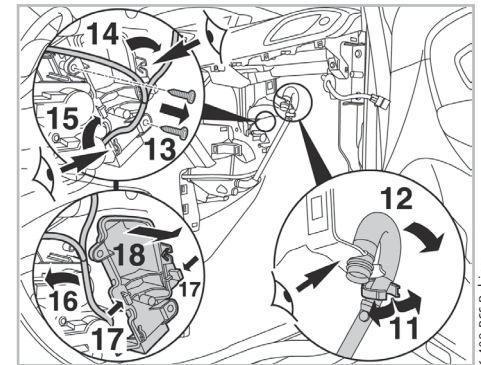
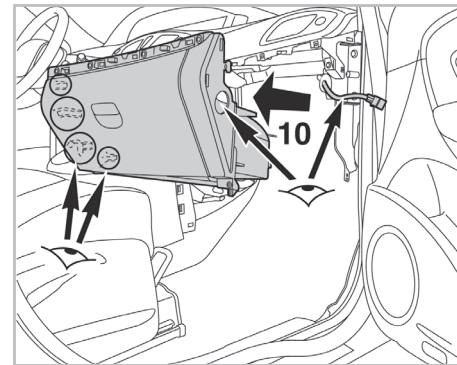
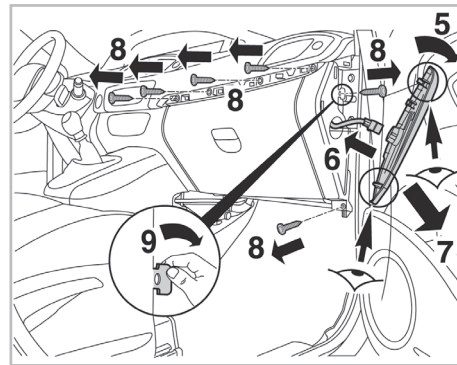
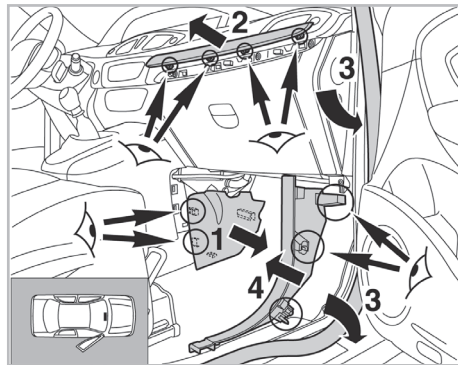

Valeo Service - Société par Actions simplifiée - Capital de 12 900 000 € - 70, rue Playel, 93285 Saint-Denis Cedex - France - B 306 486 408 RCS Bobigny